



GUIDELINE FOR POST-EARTHQUAKE DAMAGE EVALUATION AND REHABILITATION OF RC BUILDINGS IN JAPAN

Yoshiaki NAKANO¹, Masaki MAEDA², Hiroshi KURAMOTO³, and Masaya MURAKAMI⁴

SUMMARY

This paper describes the basic concept of the Guideline for Post-earthquake Damage Evaluation and Rehabilitation of RC Buildings in Japan. In this paper, (1) the damage rating procedure based on the residual seismic capacity index consistent with the Japanese Standard for Seismic Evaluation of Existing RC Buildings, (2) its validity through calibration with observed damage due to the 1995 Hyogoken-Nambu (Kobe) earthquake, and (3) the decision policy and criteria to determine necessary actions considering earthquake intensity and damage, are mainly focused.

INTRODUCTION

To restore an earthquake-damaged community as quickly as possible, a well-prepared reconstruction strategy is most essential. When an earthquake strikes a community and destructive damage to buildings occurs, immediate damage inspections are needed to identify which buildings are safe and which are not to aftershocks following the main event. However, since such quick inspections are performed within a restricted short period of time, the results may be inevitably coarse. Furthermore, it is not generally easy to identify the residual seismic capacities quantitatively from quick inspections. In the next stage following the quick inspections, a damage assessment should be more precisely and quantitatively performed, and then technically and economically sound solutions should be applied to damaged buildings, if rehabilitation is needed. To this end, a technical guide that may help engineers find appropriate actions required for a damaged building is most essential.

In Japan, the Guideline for Post-earthquake Damage Evaluation and Rehabilitation (JBDPA [1]) originally developed in 1991 was recently revised considering damaging earthquake experiences in Japan. The main objective of the Guideline is to serve as a technical basis and to provide rational criteria when an engineer needs to identify and rate building damage quantitatively and to determine necessary actions required for the building, and to provide technically sound solutions to restore the damaged building. It describes a

¹ Institute of Industrial Science, The University of Tokyo, Tokyo, Japan. Email: iisnak@iis.u-tokyo.ac.jp

² Department of Architecture and Building Science, Tohoku University, Sendai, Japan.

³ International Cooperation Center of Engineering Education Development, Toyohashi University of Technology, Toyohashi, Japan.

⁴ Advanced Research Institute for Science and Engineering, Waseda University, Tokyo, Japan.

damage evaluation basis and rehabilitation techniques for three typical structural systems in Japan, i.e., reinforced concrete, steel, and wooden buildings. This paper discusses the outline and the basic concept of the Guideline for reinforced concrete buildings, primarily focusing on (1) the damage rating procedure based on the residual seismic capacity index that is consistent with the Japanese Standard for Seismic Evaluation of Existing RC Buildings (JBDPA [2]), (2) its validity through calibration with observed damage due to the 1995 Hyogoken-Nambu (Kobe) earthquake, and (3) the decision policy and criteria to determine necessary actions considering earthquake intensity and damage to a building.

OBJECTIVE AND SCOPE

The Guideline is designed primarily for cast-in-place reinforced concrete buildings with less than some 10 stories designed and constructed before 1981, since they are most vulnerable as was found in the past major damaging earthquakes in Japan. A residual seismic capacity index newly employed in the revised Guideline is designed to be consistent with the Japanese Standard for Seismic Evaluation of Existing RC Buildings, which basically applies to medium- to low-rise reinforced concrete buildings.

Higher buildings may be exposed to earthquake induced high axial forces, which give more significant influences on the strength and ductility of columns. Furthermore, their failure may cause catastrophic consequences to the building and community. The Guideline, therefore, recommends the higher buildings need to be more carefully surveyed and judged in addition to the results based on this Guideline.

The Guideline consists of 4 major sections:

(1) Damage rating of foundation and superstructure

The damage to each structural member is inspected and classified into one of damage classes I through V. Then the residual seismic capacity ratio index R is calculated and the overall damage rating of the building is performed based on R -index.

(2) Determination of rehabilitation actions

Based on the damage rate made in (1) above and the intensity of shaking experienced at the building site, necessary rehabilitation actions such as repair and strengthening are determined.

(3) Visual instructions for repair and strengthening

In the Guideline, approximately 50 techniques are illustrated with recommended redesign details as well as rehabilitation procedures.

(4) Application examples

Finally two example buildings, which were damaged during the 1994 Sanriku-haruka-oki earthquake and the 1995 Hyogoken-Nambu earthquake, are presented to help engineers understand the concept of the Guideline and its application procedure.

In the subsequent sections, damage rating and decision criteria for rehabilitation level are described.

DAMAGE EVALUATION AND REHABILITATION

General flow

Damage evaluation of a building is performed on foundation system and superstructure system, respectively, and the damage rating of each building is made in a combination form for each system such as “no damage in foundation and moderate damage in superstructure”. Rehabilitation actions necessary for the building are then determined considering identified damage. **Figure 1** shows the general flow of damage evaluation and subsequent rehabilitation actions.

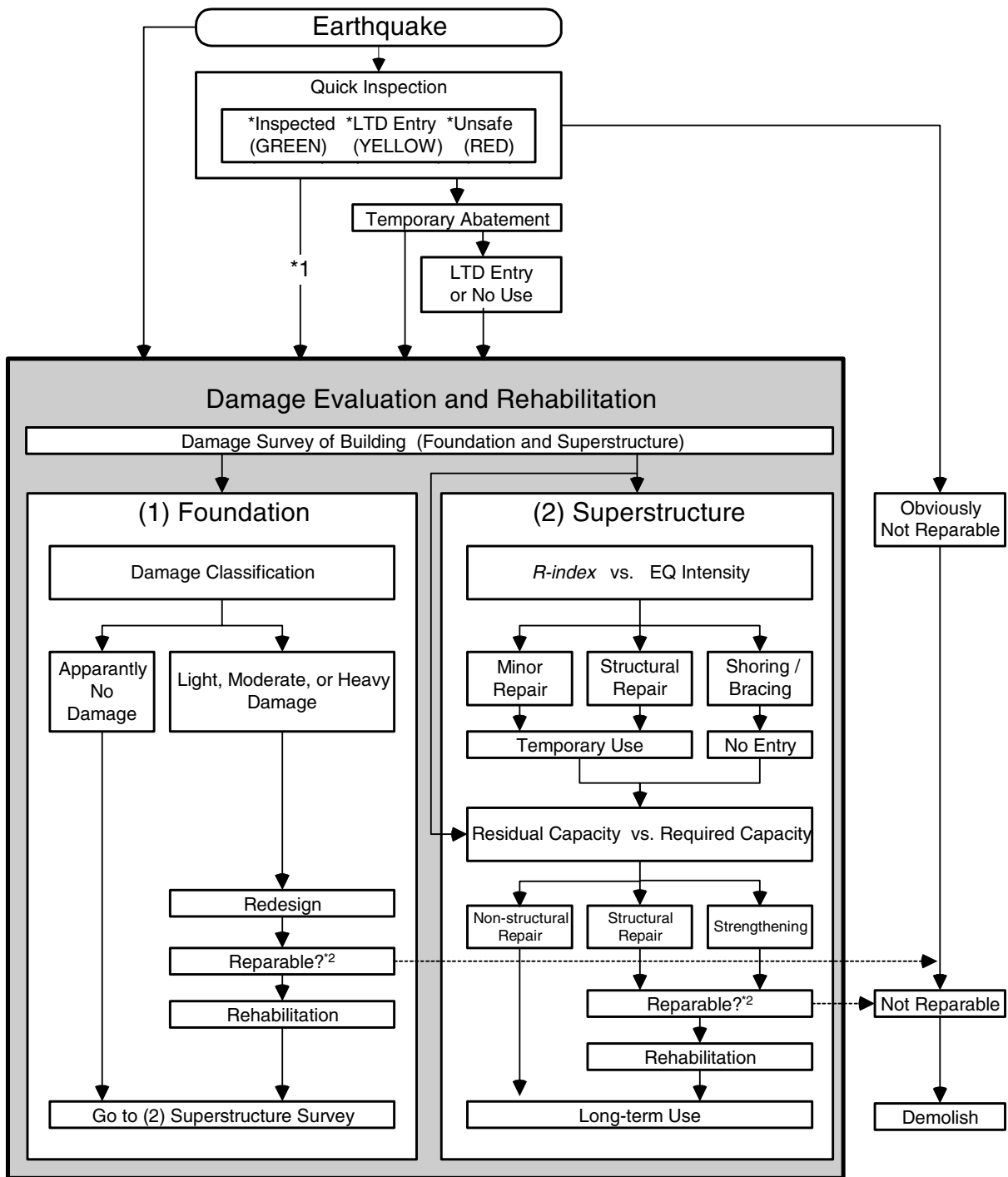

*1 Damage evaluation fundamentally includes buildings after quick inspection since the inspection results do not necessarily provide sufficient information related to the residual seismic capacity which is most essential to judge appropriateness of continued long-term use of buildings.

*2 Economic as well as technical issues should be considered.

Figure 1: General Flow of Damage Evaluation and Rehabilitation Assumed in the Guideline

Foundation

In general, foundation damage concurrently causes two major evidences, i.e., building settlement (S) and foundation leaning (θ), and the Guideline defines the foundation damage in the matrix form of these two evidences. Foundation leaning may be identified from the leaning of an entire building unless the superstructure has apparent damage and/or localized residual story drift along the building height.

(1) Damage rating of foundation

Table 1 shows the damage classification of (a) pile foundations and (b) footing and mat foundations, respectively. Leaning of foundation (θ) may be determined from the tilting angle in each principal axis (θ_x and θ_y) of a building superstructure defined in **Eq.(1)**, unless apparent residual story drift due to localized structural damage can be found in the building superstructure.

$$\theta = \sqrt{\theta_x^2 + \theta_y^2} \quad (1)$$

where, θ_x and θ_y signify the tilting angle in the principal axis X and Y of a building superstructure.

Leaning criteria between damage and no damage is determined considering damage experiences in the 1995 Kobe earthquake. Excavation surveys after the event show that (1) all buildings with a tilting angle of more than 1/100 rad. and 2/3 of those with 1/100 to 1/300 rad. had damage in pile foundation, and (2) no buildings having footing or mat foundations with a tilting angle of less than 1/150 rad. were rehabilitated. Another criteria is determined from the evidence that (1) pile foundations experienced extensive damage when they had more than 0.3 m settlement and some damage when they had less than 0.3 m but more than 0.1 m settlement, and (2) footing and mat foundations were repaired when they had more than 0.05 m settlement. Note that a large settlement is unlikely to occur together with slight leaning and the Guideline therefore does not intend to cover such damage combination as indicated by “*” in **Table 1**.

Table 1: Damage Classification Criteria of Foundations

| (a) Pile Foundations | | | | | (b) Footing and Mat Foundations | | | | | | |
|----------------------|-------|--------------------|----------|----------|---------------------------------|-----------------|-------|--------------------|----------|----------|-------|
| θ (rad.) | | Settlement S (m) | | | | θ (rad.) | | Settlement S (m) | | | |
| | | 0 | 0.1 | 0.3 | 0.05 | | | 0.1 | 0.3 | | |
| Tilting | 1/300 | None | Light | Moderate | * | Tilting | 1/150 | None | Light | * | * |
| | 1/150 | Light | Moderate | Moderate | Heavy | | 1/75 | Light | Moderate | Moderate | * |
| | 1/75 | Moderate | Moderate | Heavy | Heavy | | 1/30 | Moderate | Moderate | Heavy | Heavy |
| | | Heavy | Heavy | Heavy | Heavy | | | Heavy | Heavy | Heavy | Heavy |

* Not covered in the Guideline and more careful examinations needed

(2) Rehabilitation criteria

The Guideline fundamentally intends to restore the foundation to its pre-damaged condition primarily because the foundation strengthening may results in damage to building superstructures during a subsequent event unless the superstructures are upgraded as well, and generally costly rehabilitation is required to upgrade both foundations as well as building superstructures. However the Guideline recommends that heavily damaged foundations should be properly upgraded for long-term use especially when the damage is attributed to minor to moderate shaking intensity.

Building superstructure

An inspection engineer first surveys structural damage and performs damage classifications of structural members in the most seriously damaged story of a building. The residual seismic capacity ratio index R is

then calculated and the damage rating of the building superstructure, i.e., [slight], [light], [moderate], [heavy], and [collapse] is made. Necessary actions are finally determined comparing the ground shaking experienced at the building site, damage rate of the building, and seismic capacity required against a future earthquake.

(1) *Damage classification of structural members*

A damage classification of columns and shear walls is performed based on the damage definition shown in **Table 2** and **Photo 1**. As was revealed in the past damaging earthquakes in Japan, typical life-threatening damage is generally found in vertical members, and the Guideline is essentially designed to identify and classify damage in columns and walls rather than in beams. When damage is found in beams, the damage classification needs to be performed considering their deficiency in vertical load carrying capacity as well as lateral resisting of columns adjacent to damaged beams. As defined in **Table 2**, columns and walls are classified in one of five categories I through V. **Figure 2** schematically illustrates the load carrying capacity, load-deflection curve, and member damage class.

Table 2: Damage Class Definition of RC Columns and Walls

| Damage Class | Description of Damage |
|--------------|---------------------------------------------------------------------------------------------------------------------------------------------------------------------------------------------|
| I | - Visible narrow cracks on concrete surface (Crack width is less than 0.2 mm) |
| II | - Visible clear cracks on concrete surface (Crack width is about 0.2 -1.0 mm) |
| III | - Local crush of concrete cover - Remarkable wide cracks (Crack width is about 1.0 - 2.0 mm) |
| IV | - Remarkable crush of concrete with exposed reinforcing bars - Spalling off of concrete cover (Crack width is more than 2.0 mm) |
| V | - Buckling of reinforcing bars - Cracks in core concrete - Visible vertical and/or lateral deformation in columns and/or walls - Visible settlement and/or leaning of the building |

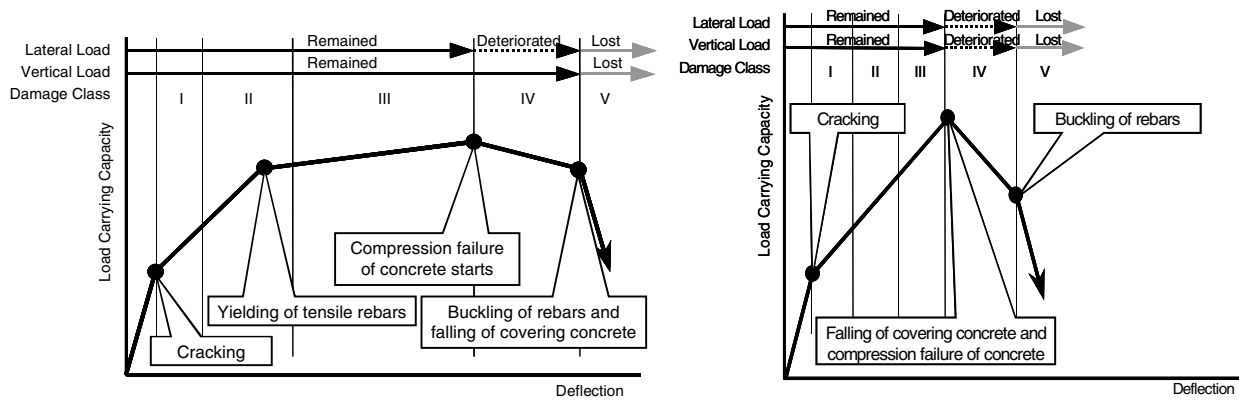

(a) Ductile Member

(b) Brittle Member

Figure 2: Damage Class vs. Load Carrying Capacity

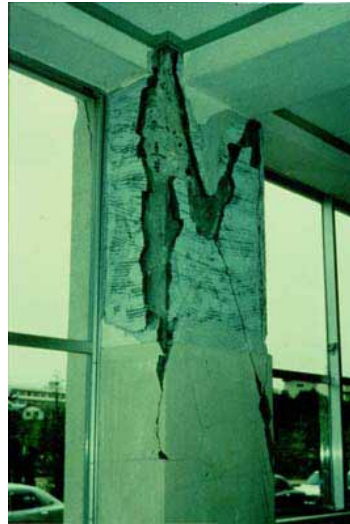

Damage class III:
(left) Cracks with a width of about 2mm on structural concrete
(right) Spalling concrete cover and slightly exposed rebar



Damage class IV:
Exposed rebar without buckling or fracture



Damage class V

Photo 1: Damage Class Examples

(2) *Residual Seismic Capacity Ratio Index R*

A residual seismic capacity ratio index R , which corresponds to building damage, is defined as the ratio of capacity of post-damaged to that of pre-damaged condition (i.e., the ratio of the residual capacity to the original).

$$R = \frac{D I_s}{I_s} \times 100 \quad (\%)$$

where, I_s : seismic capacity index of structure before earthquake damage (2)
 $D I_s$: seismic capacity index of structure considering deteriorated member capacity

I_s -index can be calculated based on the concept found in the Japanese Standard for Seismic Evaluation (JBDPA [2]), which is most widely applied to evaluate the seismic capacity of pre-damaged existing buildings in Japan. The basic concept of the Standard to calculate I_s -index can be found in **Appendix**. The Guideline recommends to calculate $D I_s$ -index for a damaged building in the analogous way, considering a seismic capacity reduction factor η which is defined as the ratio of the absorbable hysteretic energy after an earthquake to the original absorbable energy of structural members as illustrated in **Figure 3**. **Table 3** shows the reduction factor η defined in the Guideline, where several experimental results shown in **Figure 4** (Maeda et al. [3]) are taken into account for the values. It should be noted that the residual member strength is simply calculated by the product of reduction factor η and the original strength assuming the pre-damaged member ductility is preserved even in the post-damaged condition, since no data are available to precisely determine ductility reduction factors of damaged members. Furthermore, experimental results related to residual capacity are still few especially for wall members and brittle columns, and more efforts should be directed toward clarifying and verifying residual performance of damaged members.

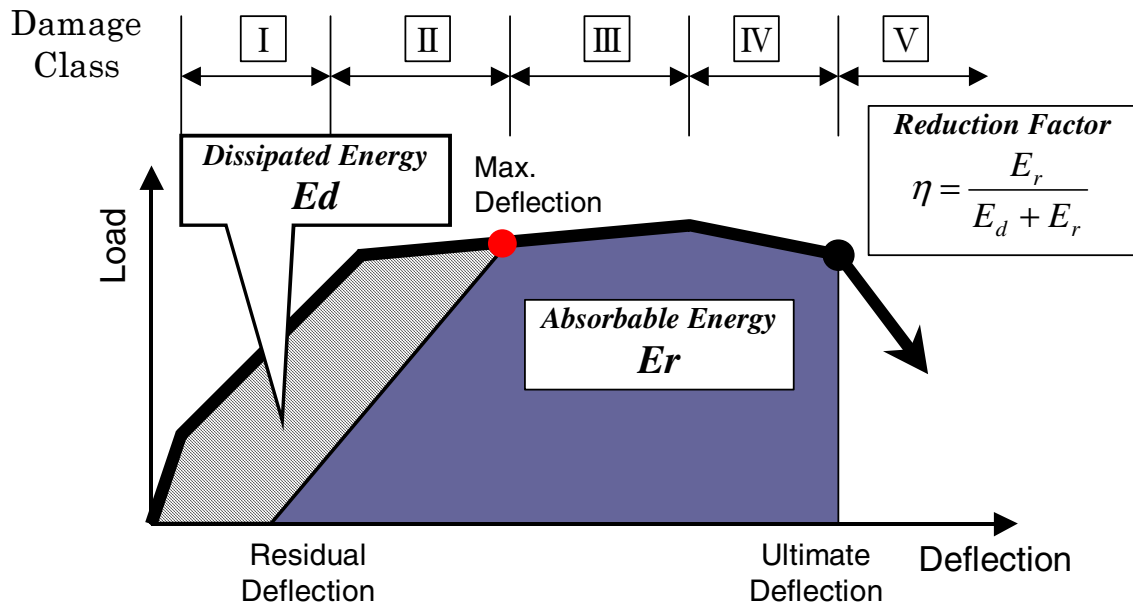
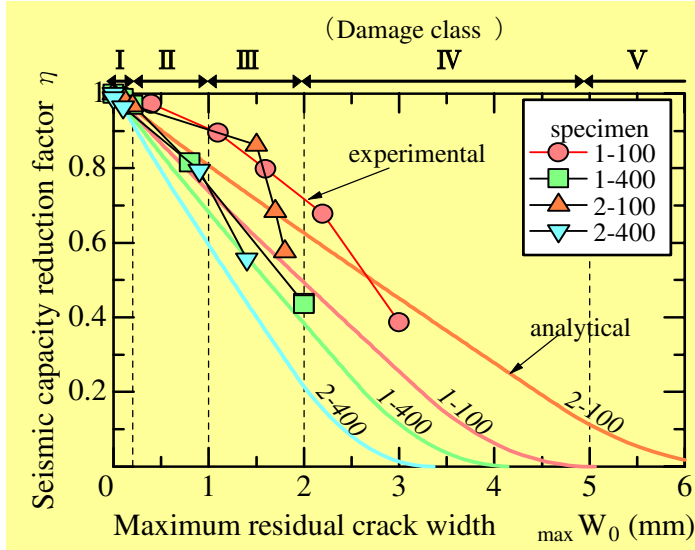

Figure 3: Basic Concept of Seismic Capacity Reduction Factor η

Table 3: Seismic Capacity Reduction Factor η (JBDPA [1])

| Damage Class | Brittle Column* | Ductile Column* | Wall w/o Boundary Columns* | Column w/ Wing Wall(s)* | Wall w/ Boundary Columns* |
|--------------|-----------------|-----------------|----------------------------|-------------------------|---------------------------|
| I | 0.95 | 0.95 | 0.95 | 0.95 | 0.95 |
| II | 0.60 | 0.75 | 0.60 | 0.60 | 0.60 |
| III | 0.30 | 0.50 | 0.30 | 0.30 | 0.30 |
| IV | 0 | 0.10 | 0 | 0 | 0 |
| V | 0 | 0 | 0 | 0 | 0 |

* Typical section configurations can be found in Table 4.



Note: Experimental results (Maeda et al. [3]) for 4 beam specimens subjected to cyclic loadings are shown here, where the relationship between the reduction factor η calculated in accordance with the concept shown in **Figure 3** and the maximum residual crack width $maxW_o$ is plotted. Curves shown together in the figure are obtained assuming Takeda hysteretic model.

Figure 4: Seismic Capacity Reduction Factor η Obtained from Experimental Investigations

After the Kobe earthquake, seismic evaluation has been performed for numerous buildings, and when the evaluation results including member strength and ductility of pre-damaged condition are available, they would greatly help engineers calculate the R -index. Most buildings that have been seismically evaluated, however, are public use buildings such as schools and central/local government buildings, and other building data available are still limited.

The Guideline, therefore, proposes an alternative procedure to calculate R -index in a simplified way. This procedure would efficiently help engineers rate building damage and identify necessary rehabilitation actions to be taken on a building, especially when the earthquake damage is widespread and a large number of buildings need to be rated. In the simplified procedure, a normalized strength index \bar{C} for each typical member section which often appears in existing RC buildings in Japan are proposed considering ultimate shear stress and effective sectional area of each section type as shown in **Table 4**. Considering the strength index \bar{C} and the reduction factor η listed in **Table 3** for a damaged member, the residual seismic capacity index R can be simply expressed as shown in **Eq.(3)**.

$$R = \frac{\sum_{j=0}^5 A_j}{A_{org}} \times 100 \quad (\%) \quad (3)$$

$$A_0 = S_0 + M_0 + W_0 + 2CW_0 + 6CWC_0$$

$$A_1 = 0.95S_1 + 0.95M_1 + 0.95W_1 + 1.9CW_1 + 5.7CWC_1$$

$$A_2 = 0.6S_2 + 0.75M_2 + 0.6W_2 + 1.2CW_2 + 3.6CWC_2$$

$$A_3 = 0.3S_3 + 0.5M_3 + 0.3W_3 + 0.6CW_3 + 1.8CWC_3$$

$$A_4 = 0.1M_4$$

$$A_5 = 0$$

$$A_{org} = S_{sum} + M_{sum} + W_{sum} + 2CW_{sum} + 6CWC_{sum}$$

$A_0, A_1, A_2, A_3, A_4, A_5, A_{org}$: Sum of normalized residual seismic capacity of members having damage class 0 through V and normalized seismic capacity of a building in pre-damaged condition, respectively

$S_0, S_1, S_2, S_3, S_4, S_5, S_{sum}$: Number of brittle columns having damage class 0 through V and their total number, respectively

$M_0, M_1, M_2, M_3, M_4, M_5, M_{sum}$: Number of ductile columns having damage class 0 through V and their total number, respectively

$W_0, W_1, W_2, W_3, W_4, W_5, W_{sum}$: Number of walls without boundary columns having damage class 0 through V and their total numbers, respectively

$CW_0, CW_1, CW_2, CW_3, CW_4, CW_5, CW_{sum}$: Number of columns with wing wall(s) having damage class 0 through V and their total number, respectively

$CWC_0, CWC_1, CWC_2, CWC_3, CWC_4, CWC_5, CWC_{sum}$: Number of walls with boundary columns having damage class 0 through V and their total number, respectively

Table 4: Normalized Strength Index \bar{C} for Simplified Procedure

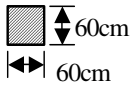
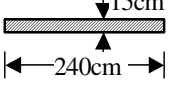
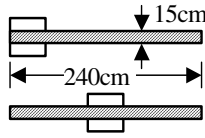
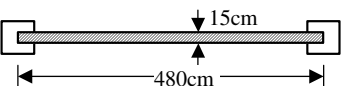
| | Ductile/Brittle Column | Wall w/o Boundary Columns | Column w/ Wing Wall(s) | Wall w/ Boundary Columns |
|---------------------------------------|-------------------------------------------------------------------------------------|-------------------------------------------------------------------------------------|--------------------------------------------------------------------------------------|---------------------------------------------------------------------------------------|
| Section |  |  |  |  |
| $\bar{\alpha}_i$ (N/mm ²) | 1 | 1 | 2 | 3 |
| \bar{C} | 1 | 1 | 2 | 6 |

(3) Damage rating of building superstructure

The residual seismic capacity ratio index R defined in (2) can be considered to represent damage sustained by a building. For example, it may represent no damage when $R = 100\%$ (100% capacity is preserved), more serious damage with decrease in R , and total collapse when $R = 0\%$ (no residual capacity). To identify the criteria for damage rating, R values, calculated from the simplified procedure shown in **Eq.(3)**, of 145 school buildings that experienced the 1995 Kobe earthquake are compared with observed damage and judgment by experts as shown in **Figure 5**. Based on the results shown in the figure, the Guideline then defines the damage rating criteria shown below.

| | |
|------------|--------------------------------------------------------------------------------|
| [Slight] | $95\% \leq R$ |
| [Light] | $80\% \leq R < 95\%$ |
| [Moderate] | $60\% \leq R < 80\%$ |
| [Heavy] | $R < 60\%$ |
| [Collapse] | Building which is deemed to have $R \approx 0$ due to overall/partial collapse |

It should be noted, however, that the boarder line between two adjacent damage rating such as [heavy damage] and [moderate damage] is not necessarily explicit, and overlapping or gray zones may be found in the figure. Those close to the damage rating criteria should be categorized after careful damage examination rather than a simple numerical judgment.

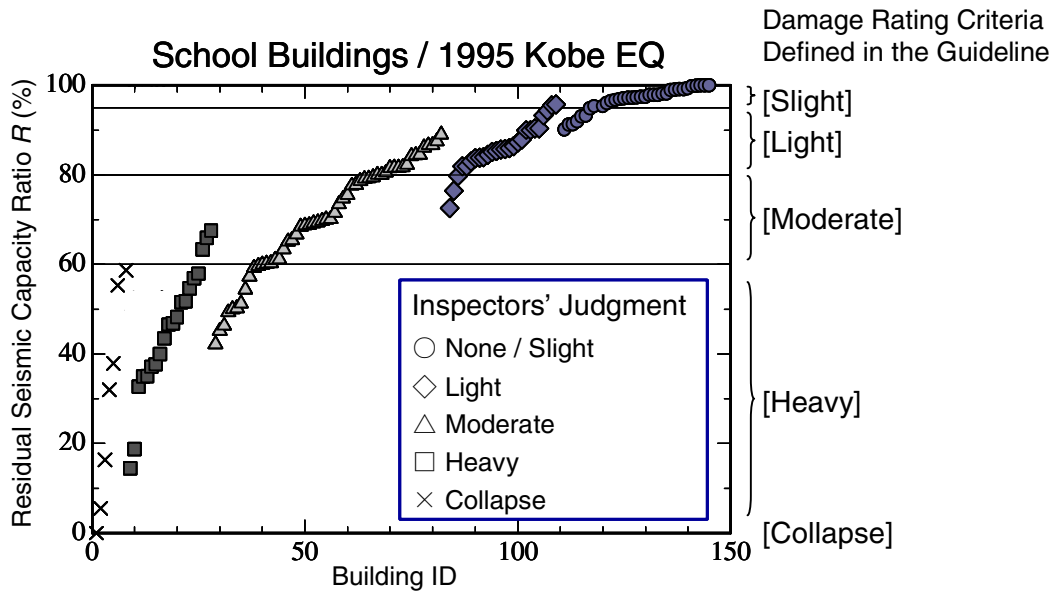

Figure 5: Residual Seismic Capacity Ratio R vs. Observed Damage

(4) Rehabilitation criteria

When a damaged building needs to be reused for a certain long period of time after its rehabilitation, the most fundamental strategy is to provide the seismic capacity required for new constructions at the site. The building should meet the criteria specified in the Standard for Seismic Evaluation, which is, as shown in **Appendix**, primarily designed for pre-damaged existing RC buildings in Japan.

In most cases, structural strengthening as well as repair is needed to meet such criteria, which is in general costly and time consuming. It should be noted, furthermore, that such a complete rehabilitation can not be made to all buildings soon after a major event, and therefore a scenario for temporary actions and their criteria should be prepared. This is especially so when the damage is extensive and widespread, and a huge number of buildings are damaged. To this end, the Guideline describes criteria for continued but temporary use after repair. **Table 5(a)** shows the basic concept to estimate the seismic capacity through comparison between earthquake intensity and observed damage, and **Table 5(b)** shows the criteria for temporary use/occupancy of damaged buildings, respectively. When a building sustains minor damage under major earthquake shaking, it is deemed to have better seismic capacity and therefore its temporarily continued use is allowed after repairing structural/non-structural members. For a long-term use, in contrast, the damaged building needs to meet the criteria required in the Seismic Evaluation Standard as stated earlier, and a complete rehabilitation is generally needed as well as structural/non-structural repair.

Damage evaluation form

To facilitate the field survey, a damage evaluation form shown in **Table 6** is provided in the Guideline. The form is designed to contain general information of the building concerned, damage classification of foundation and superstructure, simplified damage rating of the entire building, other damage observed including nonstructural members, and the rehabilitation level recommended in the Guideline.

Table 5: Criteria for Temporary Restoration

(a) Basic Concept to Estimate Seismic Capacity (b) Criteria for Temporarily Continued Use

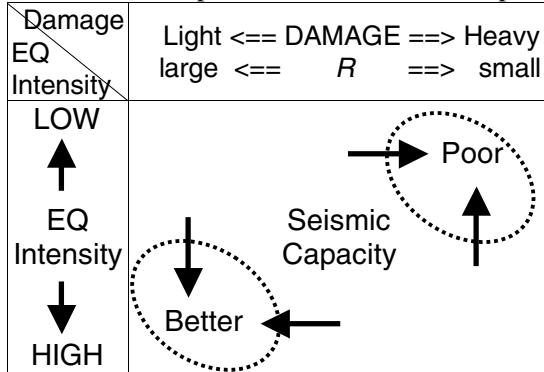

| | | | | | |
|---------------|-----|------|----|---|-----------|
| JMA (1996) | V | | VI | | VII |
| | - | + | - | + | |
| MM | VII | VIII | IX | X | XI XII |
| MSK | VII | VIII | IX | X | XI XII |

| Damage EQ Intensity | [Slight] 95 ≤ R < 100 | [Light] 80 ≤ R < 95 | [Moderate] 60 ≤ R < 80 | [≥Heavy] R < 60 |
|---------------------|--------------------------|------------------------|---------------------------|--------------------|
| ≤ V | X | X | X | X |
| V+ | A | C | C | C |
| VI- | A | B (C) | C | C |
| ≥ VI+ | A | A (B) | B (C) | C |

Note: The earthquake intensity on Japan Meteorological Agency (JMA) scale is used in the Table. Symbols in parentheses represent criteria for pre-1971 buildings that are designed to comply with less stringent requirement for shear reinforcement and therefore are deemed more vulnerable.

- A : Continued use/occupancy allowed after minor structural/non-structural repair
- B : Continued use/occupancy allowed after structural repair to restore seismic capacity of pre-damaged condition
- C : Continued use/occupancy not allowed unless the complete structural rehabilitation is performed to meet the criteria of Seismic Evaluation Standard
- X : Detailed examination required (out of scope of the Guideline)

REHABILITATION TECHNIQUES

To facilitate the rehabilitation design and construction, visual instructions consisting of 19 examples for foundation and 28 examples for superstructure are provided together with photo examples. **Figure 6** shows a typical example for building superstructure.

CONCLUDING REMARKS

Seismic evaluation and rehabilitation before damaging earthquake is definitely most essential to mitigate damage. It is also true, however, that such efforts need a certain period of time, manpower and budget to complete enormous buildings throughout the country. A well prepared post-earthquake strategy including damage evaluation and rehabilitation schemes as well as pre-event preparedness is therefore an urgent task to be developed in the researchers and engineers community, and should be ready for the immediate application after an event.

In this paper, the basic concept and procedure for post-earthquake damage evaluation of RC buildings in Japan are presented, together with background and several supporting data. As discussed herein, available data related to residual seismic capacity and their evaluation method are still few, and researchers are encouraged to direct their efforts for further understanding and clarifying structural performances after earthquakes.

Table 6: Damage Evaluation Form of RC Buildings (page 1 of 2)

Report No. _____ Inspection Date: yy/mm/dd _____ Time: _____ am / pm
 No. of inspections _____ Inspector: ID _____ Affiliation _____

1. General Description of Building

1. 1 Building Name _____
 1. 2 Address _____
 1. 3 Building Owner _____
 1. 4 Contact Person _____
 1. 5 Occupancy Office Detached Apartment Ret. Store Industrial
 Warehouse School Daycare Ctr. Gov. Office Public Hall
 Gym. Hospital Other _____
 1. 6 Structural Type RC PCa RM SRC Hybrid
 1. 7 Construction Type Concrete frame Concrete shear wall Other
 1. 8 Foundation Type Footing Mat Pile
 1. 9 Building size No. of stories above ground ___ below ground ___ Approx. size ___m x ___m
 1.10 Site Condition Flat Slope Hill Basin
 1.11 Topography ___m from Cliff River Seashore Lakeshore
 1.12 Ext. Finishing PC wall ALC Block Others
 1.13 Const. Documents Calculation Drawings Const. records
 1.14 Construction Year _____ Pre-1971 Post-1972 Unknown

2. Damage Rating

2.1 Damage rating of entire building from obvious damage

Collapse, partial collapse or obvious leaning
 Yes (Go to 2.3, skip calculations and check [collapse]) No (Go to 2.2)

2.2 Damage rating of foundation

- (1) Foundation settlement S = _____ m
 (2) Foundation leaning $\theta_x =$ _____ rad. $\theta_y =$ _____ rad. $\theta = \sqrt{\theta_x^2 + \theta_y^2} =$ _____ rad.

#1 Damage rating of foundation from settlement and leaning (see Table 1 or 2, and check one)

None Light Moderate Heavy

2.3 Damage rating of superstructure

- (1) Most seriously damaged story and its direction: _____-th story of Long. dir. Trans. dir.
 (2) Localized damage Yes No
 (3) Damage identification of structural members

| | Brittle column | Ductile column | Wall w/o boundary columns | Column w/ wing wall | Wall w/ boundary columns | Sum | | | | | | |
|--------------------|--------------------------|----------------|---------------------------|---------------------|--------------------------|-----|--------------------------|---|--------------------------|---|-----|--------------------|
| Number of elements | () | + | () | + | () | + | () | + | () | = | () | |
| Surveyed number | () ^{<1>} | + | () ^{<2>} | + | () ^{<3>} | + | () ^{<4>} | + | () ^{<5>} | = | () | |
| | <1>×1 | + | <2>×1 | + | <3>×1 | + | <4>×2 | + | <5>×6 | = | () | = A _{org} |
| DC 0 | () | + | () | + | () | + | ()×2 | + | ()×6 | = | () | = A ₀ |
| DC I | ()×0.95 | + | ()×0.95 | + | ()×0.95 | + | ()×1.9 | + | ()×5.7 | = | () | = A ₁ |
| DC II | ()×0.6 | + | ()×0.75 | + | ()×0.6 | + | ()×1.2 | + | ()×3.6 | = | () | = A ₂ |
| DC III | ()×0.3 | + | ()×0.5 | + | ()×0.3 | + | ()×0.6 | + | ()×1.8 | = | () | = A ₃ |
| DC IV | ()×0 | + | ()×0.1 | + | ()×0 | + | ()×0 | + | ()×0 | = | () | = A ₄ |
| DC V | ()×0 | + | ()×0 | + | ()×0 | + | ()×0 | + | ()×0 | = | 0 | = A ₅ |

DC denotes *Damage Class*.

$$\sum A_j = A_0 + A_1 + A_2 + A_3 + A_4 + A_5 = ()$$

Table 6: Damage Evaluation Form of RC Buildings (page 2 of 2)

(4) Residual seismic capacity ratio index R $R = \frac{\sum A_j}{A_{org}} \times 100 = \frac{(\quad)}{(\quad)} \times 100 = (\quad)$

#2 Damage rating of building superstructure from residual seismic capacity index R
 None ($R=100$) Slight ($95 \leq R < 100$) Light ($80 \leq R < 95$)
 Moderate ($60 \leq R < 80$) Heavy ($R < 60$) Collapse ($R \approx 0$)

3. Other Damage [comments]
 Floor/Roof No Yes _____
 Penthouse No Yes _____
 Exterior Staircase No Yes _____
 Chimney No Yes _____
 Connecting Corridor No Yes _____
 Exp. Joint No Yes _____
 Others No Yes _____

4. Further Actions to be Taken on the Damaged Building
 EQ Intensity on JMA Scale: VI+ or VII VI- V+ V- or lower

Table 1: Pile Foundations

| θ (rad.) | | Settlement S (m) | | | |
|-----------------|-------|--------------------|----------|----------|-------|
| | | 0 | 0.1 | 0.3 | |
| Tilting | 1/300 | None | Light | Moderate | * |
| | 1/150 | Light | Moderate | Moderate | Heavy |
| | 1/75 | Moderate | Moderate | Heavy | Heavy |
| | | Heavy | Heavy | Heavy | Heavy |

Table 2: Footing and Mat Foundations

| θ (rad.) | | Settlement S (m) | | | |
|-----------------|-------|--------------------|----------|----------|-------|
| | | 0.05 | 0.1 | 0.3 | |
| Tilting | 1/150 | None | Light | * | * |
| | 1/75 | Light | Moderate | Moderate | * |
| | 1/30 | Moderate | Moderate | Heavy | Heavy |
| | | Heavy | Heavy | Heavy | Heavy |

* Not covered in the Guideline and more careful examinations needed

Table 3: Criteria for Foundation

| Damage EQ Intensity | [Light] | [Moderate] | [Heavy] |
|------------------------|---------|------------|---------|
| $\leq V^-$ | X | X | X |
| V^+ | C | X | X |
| VI | B | C | X |
| $\geq VI^+$ | B | B | C |

Table 4: Criteria for Superstructure

| Damage EQ Intensity | [Slight] $95 \leq R < 100$ | [Light] $80 \leq R < 95$ | [Moderate] $60 \leq R < 80$ | [>Heavy] $R < 60$ |
|------------------------|-------------------------------|-----------------------------|--------------------------------|----------------------|
| $\leq V^-$ | X | X | X | X |
| V^+ | A | C | C | C |
| VI | A | B (C) | C | C |
| $\geq VI^+$ | A | A (B) | B (C) | C |

#1: Damage Rating of Foundation

No Damage Light Moderate Heavy
 Rehab. of Foundation (see Table 3) Not required (No Damage) Repair (B)
 Repair but detailed examination recommended (C)
 Detailed examination required (X)

#2: Damage Rating of Superstructure

No Damage Slight Light Moderate Heavy Collapse
 Rehab. of Superstructure (see Table 4) Not required (No Damage) Minor repair (A)
 Temporary restoration (Structural Repair) (B)
 Shoring/bracing required but continued use/occupancy not allowed until complete structural rehabilitation (C)
 Detailed examination required (X)
 Obviously temporary rehabilitation impossible (collapse or partial collapse)

5. Sketches and Comments

Shear Capacity Improvement

Applicable to: [temporary restoration] (repair) [strengthening]

Applicable Damage Class: II III IV V

1. Rehabilitation with welded wire fabric and concrete jacketing

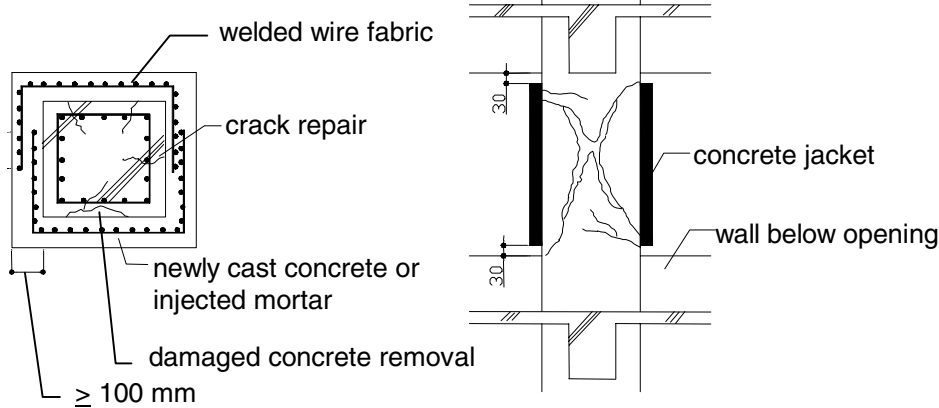

2. Rehabilitation with carbon fiber sheet

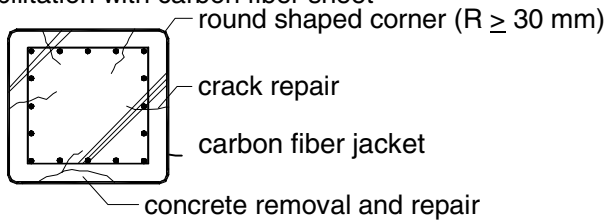

* For further information, remarks on construction procedure and those to be taken into account in designing new members are also provided in the sheet.

Figure 6: Rehabilitation Technique Example for Columns

APPENDIX BASIC CONCEPT OF JAPANESE STANDARD FOR SEISMIC EVALUATION OF EXISTING RC BUILDINGS

The Standard for Seismic Evaluation (JBDPA [2]), designed primarily for pre-damaged existing RC buildings in Japan, defines the following structural seismic capacity index I_s at each story level in each principal direction of a building.

$$I_s = E_o \times S_D \times T \tag{4}$$

where, E_o : basic structural seismic capacity index, calculated by the product of Strength Index (C), Ductility Index (F), and Story Index (ϕ) at each story and each direction when a story or a building reaches the ultimate limit state due to lateral force ($E_o = \phi \times C \times F$)

C : index of story lateral strength expressed in terms of story shear coefficient

F : index of story ductility, calculated from the ultimate deformation capacity normalized by the story drift of 1/250 when a typical-sized column is assumed to fail in shear. F is dependent

on the failure mode of a structural member and its sectional properties such as bar arrangement, member's geometric size etc. F is assumed to be in the range of 1.27 to 3.2 for ductile columns, 1.0 for brittle columns and 0.8 for extremely brittle short columns.

- ϕ : index of story shear distribution during earthquake, estimated by the inverse of design story shear coefficient distribution normalized by the base shear coefficient. $\phi = (n+1)/(n+i)$ is basically employed for the i -th story of an n story building
- SD : reduction factor to modify E_o index due to stiffness discontinuity along stories, eccentric distribution of stiffness in plan, irregularity and/or complexity of structural configuration, basically ranging from 0.4 to 1.0
- T : reduction factor to allow for time-dependent deterioration grade, ranging from 0.5 to 1.0

A required seismic capacity index I_{so} , which is compared with I_s -index to identify structural safety against an earthquake, is defined as follows.

$$I_{so} = E_s \times Z \times G \times U \quad (5)$$

where, E_s : basic structural seismic capacity index required for the building concerned. Considering past structural damage due to severe earthquakes in Japan, the standard value of E_s is set 0.6.

- Z : factor allowing for the seismicity
- G : factor allowing for the soil condition
- U : usage factor or importance factor of a building

Typical I_{so} index is 0.6 considering $E_s = 0.6$ and other factors of 1.0. It should be noted that $CT \times SD$ defined in **Eq.(6)** is required to equal or exceed $0.3 Z \times G \times U$ in the Standard to avoid fatal damage and/or unfavorable residual deformation due to a large response of structures during major earthquakes.

$$CT \times SD = \phi \times C \times SD \quad (6)$$

Seismic rehabilitation of existing buildings is basically carried out in the following procedure.

- (1) Seismic evaluation of the structure concerned (I_s and $CT \times SD$)
- (2) Determination of required seismic capacity (I_{so})
- (3) Comparison of I_s with I_{so} and of $CT \times SD$ with $0.3 Z \times G \times U$
 - * If $I_s < I_{so}$ or $CT \times SD < 0.3 Z \times G \times U$ and therefore rehabilitation is required, the following actions (4) through (6) are needed.
- (4) Selection of rehabilitation scheme(s)
- (5) Design of connection details
- (6) Reevaluation of the rehabilitated building to ensure the capacity of redesigned building equals or exceeds the required criteria

REFERENCES

1. The Japan Building Disaster Prevention Association (JBDPA), "Guideline for Post-earthquake Damage Evaluation and Rehabilitation", 1991 (revised in 2001). (in Japanese)
2. The Japan Building Disaster Prevention Association (JBDPA), "Standard for Seismic Evaluation of Existing Reinforced Concrete Buildings", 1977(revised in 1990 and 2001). (in Japanese)
3. Masaki Maeda and Masahiro Bunno, "Post-earthquake damage evaluation for RC buildings based on residual seismic capacity in structural members", US-Japan Workshop on Performance Based Seismic Design of Reinforced Concrete Building Structures, Seattle, August 19-20, 2001.